

THIS DRAWING IS UNPUBLISHED. RELEASED FOR PUBLICATION  
 © COPYRIGHT BY TYCO ELECTRONICS CORPORATION. ALL RIGHTS RESERVED.

LOC	DIST	REVISIONS			
P	LTR	DESCRIPTION	DATE	DWN	APVD
AF	50	E3	REVISED PER ECR-08-001496	18JAN08	HMR GP

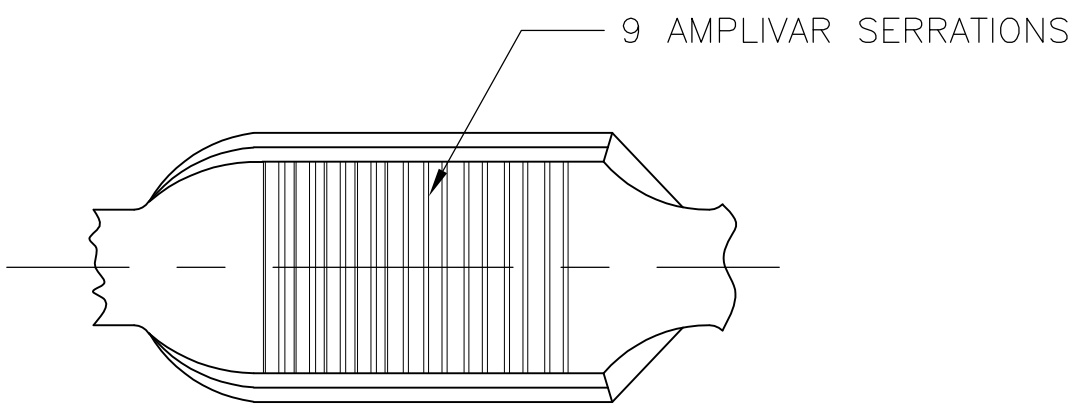

- 1 PRODUCT PROVIDED IN STRIP FORM ON REELS; BREAKS MAY BE PRESENT.
- 2 DIMENSIONS IN BRACKETS ARE IN INCHES.
- 3 CRIMP WIDTH: .110 F (AMPLIVAR TYPE)  
 CRIMP HEIGHT (±.002)=(TOTAL CMA +10,700)/193,400  
 GENERAL APPLICATION GUIDELINES MUST BE FOLLOWED AS SPECIFIED IN CATALOG # 82221  
 FOR APPLICATOR INFORMATION CALL: 1-800-722-1111  
 FOR PRODUCT INFROMATION CALL: 1-800-522-6752

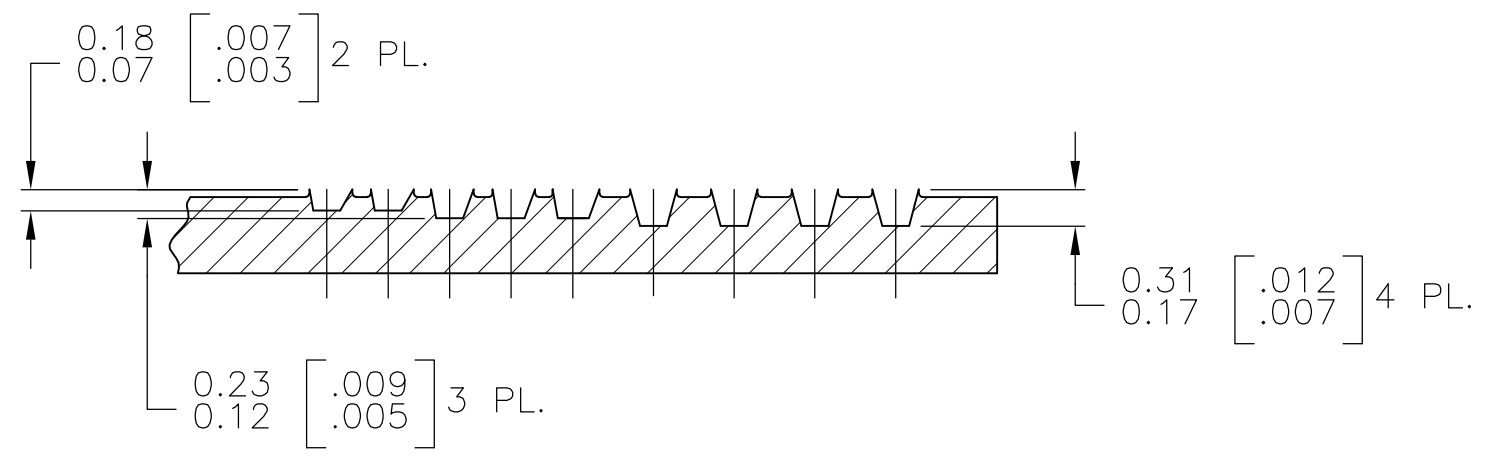
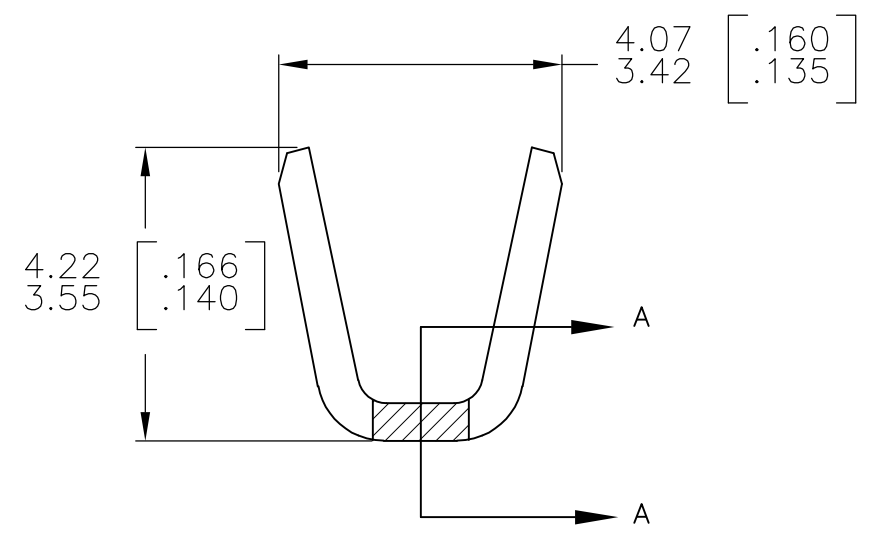
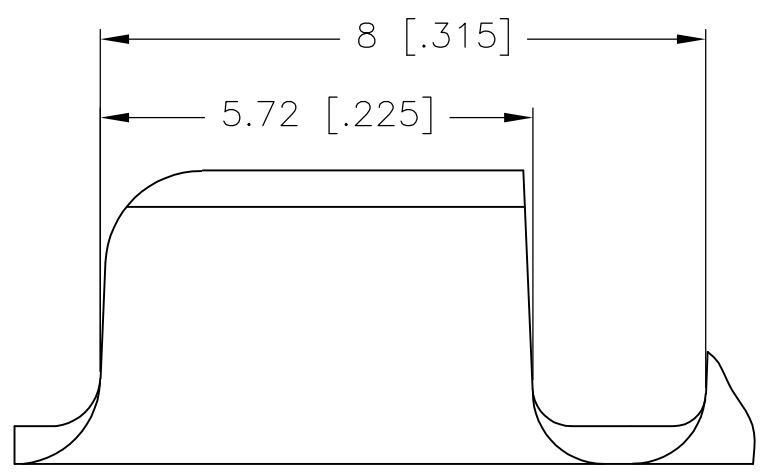

SECTION A-A  
 SCALE : 20:1

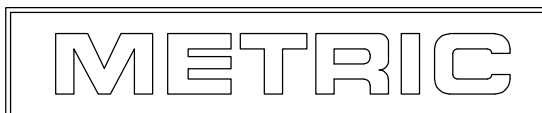

62306-2  
 PART NO.

THIS DRAWING IS A CONTROLLED DOCUMENT.		DWN RAGHAVENDRA 31JAN06	Tyco Electronics Corporation Harrisburg, PA 17105-3608	
DIMENSIONS: mm [INCHES]		CHK G.D.PORTA	NAME	
TOLERANCES UNLESS OTHERWISE SPECIFIED:		APVD G.D.PORTA	SPLICE, AMPLIVAR 1500-5000 CMA	
0 PLC ± -		PRODUCT SPEC -	APPLICATION SPEC	
1 PLC ± -		114-2003	SIZE A3	CAGE CODE 00779
2 PLC ± 0.38[.015]		WEIGHT -	DRAWING NO C-62306	RESTRICTED TO -
3 PLC ± -		CUSTOMER DRAWING		
4 PLC ± -		SCALE 10:1		
ANGLES ± 1°		SHEET 1 OF 1		
MATERIAL 0.51[.020] BRASS	FINISH TIN PL.	REV E3		